

S&C A2 June 2016 Model Answer

Question 1)

Electrical wire:

The most commonly used material for electrical wire is Copper. This is due to its high conductivity, good tensile strength and relatively low cost. Other metal can be used, such as steel when higher tensile strength is needed or gold when better connectivity is needed. Once the copper is drawn out into a cable using a continuous production method, it can be annealed to give it good flexibility as well as stranded to help further with this. Copper can easily be joined together with other copper cables using the soldering method.

An external casing for a barbeque:

A good material to use for a barbeque is stainless steel. It is excellent for retaining the contents of the barbeque, it is highly heat resistance with a very high melting point, ability to be shaped and joined, corrosion resistance. These are usually produced using a batch production method where the shape is stamped using a die and cast.

A traffic cone:

The traffic cone can be made from rubber or a thermoplastic, such as PVC. These can be brightly coloured to warn motorists of danger and are resistant to elements, tough, suitable for injection moulding or another suitable process, available in suitable colours. A continuous production, such as flow moulding.

A bird feeding table:

A good bird feeding table can be made from any material that can withstand the elements but will still be hygienic, easily cleaned. Good examples of this are hardwoods, plastics, or concrete. It would need to be easily joined which all 3 listed are as well as be aesthetically pleasing. They can be produced using either a one-off production or batch production, depending on whether it is made for personal use or for sale. The hardwoods would need to be treated to resist corrosion.

Question 2)

The two processes I would use to test an electronic circuit before putting this into production would be using CAD circuit simulation software as well as breadboarding methods.

Using circuit simulation software allow the user to quickly build and design many circuits or variants of a circuit without the need for using physical components. The connections would be very reliable and the circuits are easy to follow and fault find on. The software however is usually very expensive and does not often simulate the 'real world' properties accurately.

Breadboarding allows the user to build a 'real world' circuit using physical components to test the working of all the inputs, processes and outputs prior to PCB manufacture. The breadboards are however very difficult to wire as they are connected in patterns which do not follow the circuit diagram. There are often poor electrical connections as they are merely held in place using a clip and it is very difficult to fault find using the breadboard layout. There is also the cost of the physical components and the repair if they are damaged due to poor circuit design or connections.

Question 3)

Piano keyboard:

The following anthropometric data could be used to determine the size and shape of the product. Length of fingers, separate parts of fingers, width of hand, width of fingers, spread of fingers and force the fingers can produce. This data should be referenced to its effect on the dimensions and attributes of the keyboard.

The handle of a hammer:

The following anthropometric data could be used to determine the size and shape of the product. Length of fingers, width of hand, width of fingers, grip of the hand and force it can produce. The length of the forearm for swinging the hammer This data should be referenced to its effect on the dimensions and attributes of the handle.

A drinking mug:

The following anthropometric data could be used to determine the size and shape of the product. Length of fingers, width of hand, width of fingers, grip of the hand and force it can produce. This data should be referenced to its effect on the dimensions and attributes of the mag body and the size and shape of the handle.

A staircase:

The following anthropometric data could be used to determine the size and shape of the product. Length and width of foot, length of parts of leg, articulation range of leg. This data should be referenced to its effect on the dimensions of the tread and riser of the staircase. The weight of individuals could also be considered when considering the forces acting on the staircase.

Question 4)

When using a one-off or batch production method, the setup costs are lower than that of a CNC system. The one-off setup requires an operator who would have spent time learning and perfecting their skills, this could be said for a CNC operator setting up a machine to run. The one-off process allows for easy changes or modifications during the making process and requires very little setup time as the operator will follow a basic design to complete the project. This however allows for greater inaccuracy and human error, as mistakes can be made and there is no turning back once the piece has been cut. This makes it very difficult to repeat the process over and over and get exactly the same results.

CNC machining requires a greater setup cost and takes more time to prepare and setup the machine, including detailed CAD drawings which needs to be developed to allow this to be converted to machine code for the CNC machine to follow. Once this is all setup the machine can then operate on its own and produce exactly the same piece repeatedly with high accuracy. If however, there is a fault, then all of these piece would have been produced exactly the same with the same flaw which could have been picked up by a machinist in a one-off/batch production process.

Question 5)

Method 1:

Energy can be stored as compressed air using a compressor. The air is stored in a steel cylinder with a cut off valve allowing the cylinder to be pressurised using an electric motor until a desired pressure is reached and the motor will be switched off. Once this is done the compressed air can be used to power pneumatic power tools. The capacity could be increased or decreased depending of the size of the cylinder and pump being used. As the air is released from the tank/cylinder, the air can flow over an impellor at high pressure, forcing it to turn and drive tools. This is limited to the size of the tank and the strength of the compressor and motor combination. The tank will also not store this energy for an indefinite amount of time as the air will slowly leak out of the system, past the seals etc.

Method 2:

Energy can also be stored in a chemical form, such as petrol. This chemical can be stored in tanks and is only limited by the size of the tank. The chemical energy can be converted to heat energy which can in turn boil water to drive a steam powered electrical power stations. This a not a sustainable resource and pollutes the atmosphere but is widely used in industry to produce electricity and drive automobile engines. This process of burning fuel is limited to the capacity of the machine it is operating and will require regular re-filling as the liquid burns it will use up the fuel until there is no more.

Method 3:

Energy can also be stored using a chemical reaction system, such as a battery. This system uses to dissimilar materials placed in an electrolyte. This process forces electrons to move through the electrolyte from one material to another. Converting chemical energy to electrical energy. This can be stored in a cell, the size of the cell and types of materials used will determine the capacity of the cell and how much electrical energy it can deliver. The cell will store energy, but it starts to allow the electrons to move immediately after production, therefore a cell has a shelf life and will continue to discharge even if it is not being used. This process can be reversed with certain materials, allowing for the cell to recharge. This electrical energy can be used to power many devices, such as radios, power tools.

Question 6)

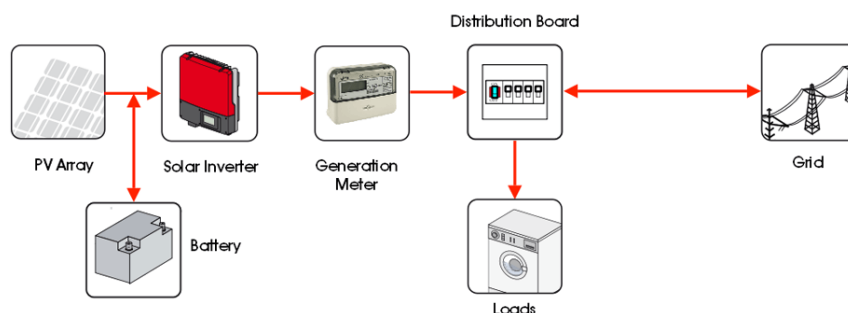

Looking at the diagram above, solar energy can be harnessed using photo voltaic (PV) cells. This energy can be stored using rechargeable batteries. Once the batteries are charged, the DC electrical energy can be converted into AC electrical energy using the Solar inverter and fed to the distribution panel in the home via a meter for billing purposes. This can be used to drive any loads, such as washing machines etc. The excess power generated can be fed into the national grid to allow other users to use the energy.

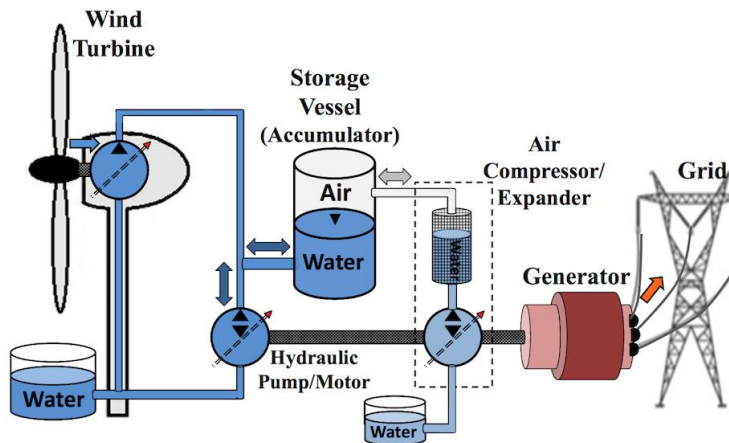

As seen in the diagram above, Wind energy can be used to pump water into a storage vessel/accumulator whilst the wind is blowing. When the accumulator fills with water, it will compress the air above it which can be sent to an air compressor which can be used to drive a generator, producing electricity which could be sent into the national grid. When the wind stops blowing, the water stored in the accumulator can then be released to and drive a hydraulic pump/motor which can then drive the generator, also delivering power to the national grid.

Question 7)

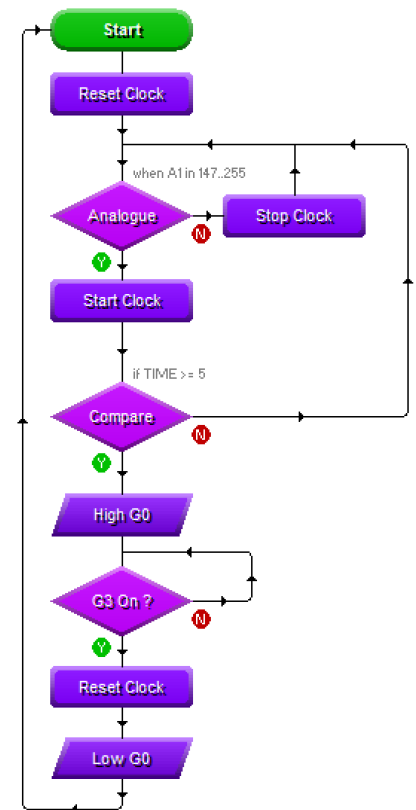
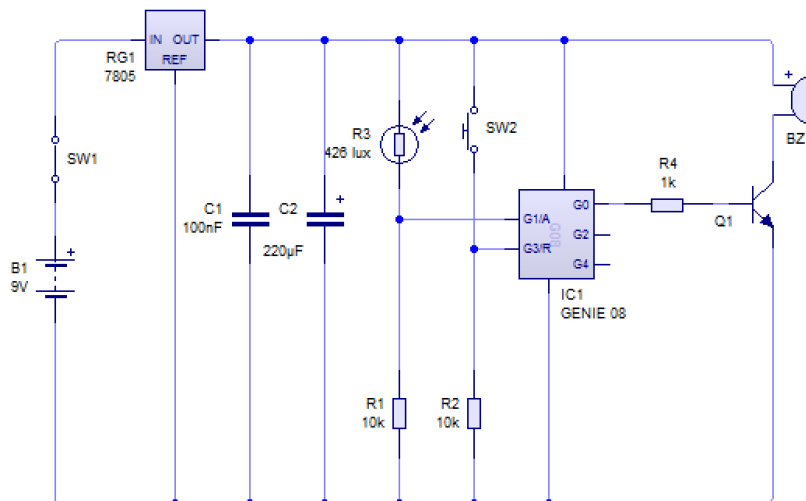

The circuit above will measure the light level an LDR (light dependant resistor) to create an analogue input which the microcontroller can monitor. The microcontroller will monitor the analogue input from the LDR and when the light level, or intensity of the sunlight reaches a specified level, it will start an internal clock. When the light intensity drops below this level the clock will stop 9 the clock is reset at the start). The length of time can be set by the user, depending on the time they want to spend in the sunshine. This time is then monitored, when the time reaches the specified limit, the output G0, which is connected to a transistor and then a buzzer which will sound when the time has been reached. The entire system can be reset when the digital input (PTM switch) goes high. The clock is then reset and the output G0 (connected to the transistor/buzzer) goes low. The program then starts the timing gain.

Question 8)

Stepper motors can be used to control CNC machines. These produce rotary motion by energising coils which force the rotor to align with the stator. As the stator coils rotate/energise in a circular motion the rotor will follow each step, usually 1.5 degrees. This is very useful as the coils can be pulsed by a microcontroller and the number of pulses will determine the exact number of moves it has made as well as the number of full rotations. This can be converted to positions on a machine bed, X, Y and Z using multiple stepper motors. These are usually connected to the bed via belt drives of threaded bars to allow the linear motion. There are no feedback requirements during the process. During the initial start-up process, the motors will need to be 'set to zero' suing micro switches to determine where the stepper motors start from.

DC motors are not suitable for CNC machines as there is no way to control the number of revolutions they make whilst producing the rotary motion. They will need a secondary feedback loop to control the position they are in. This usually requires monitoring the output or controlled devices position. This can be done via optic sensors, or magnetic drums feeding the position back to the computer controller. The speed of the motor can be controlled fairly accurately, and they have very good starting torque, this makes them very useful on production line systems. They can drive conveyer belt systems with sensors along the way to determine the position of the belt. The motor requires a DC power source, so this will need a power supply to convert the usual AC supply to DC.

Electro-pneumatics are very good at controlling industrial processes. The use a combination of air (pneumatics) and electrically or mechanically controlled valves to control the pneumatic rams. These provide linear or reciprocating motion. This system using a compressed air cylinder to provide the pneumatic pressure. Valves are the used to control whether or not the cylinder moves in or out. This can be used to lift pieces on a production line, or move them to another position. This will automate the production line.

Question 9)

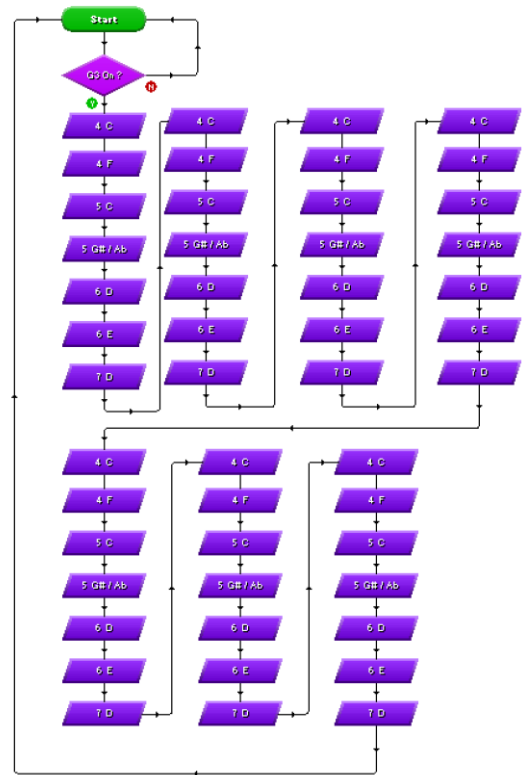
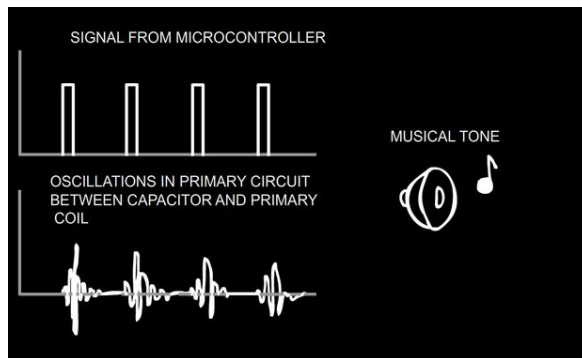
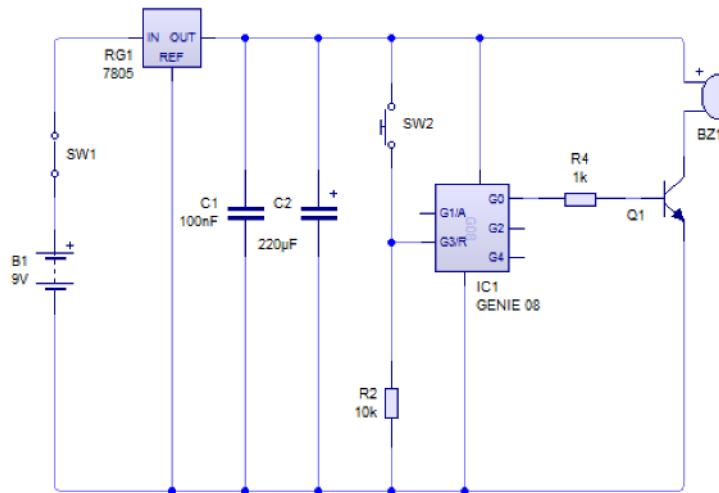

Using Circuit Wizard, there is an in-built tune block. The basic working principle is pulse width modulation (PWM). This controls the width of the pulse, which is the same as producing the frequency that you need to produce the tone you want. In the program, which is stored in the microcontroller, the digital input (switch) is connected to G3 and is used to trigger the tone sequence. The notes are activated by pulsing the output G0 which is connected to the transistor/buzzer combination, producing the frequency required to create the tone on the buzzer. This can also be created using Arduino and producing an output frequency.

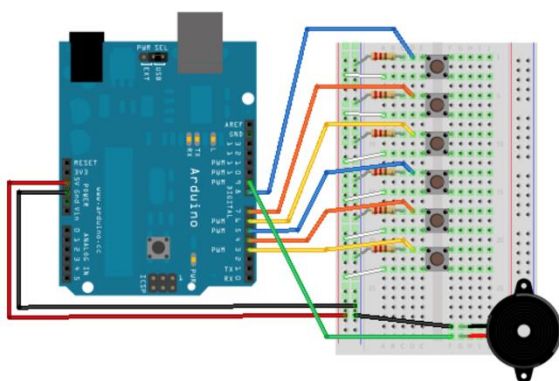

```
#define BUTTON1_PIN 3
#define BUTTON2_PIN 4
#define BUTTON3_PIN 5
#define BUTTON4_PIN 6
#define BUTTON5_PIN 7
#define BUTTON6_PIN 8
#define BUZZER_PIN 9

#define FIRST_BUTTON BUTTON1_PIN
#define LAST_BUTTON BUTTON6_PIN

#define FREQ_C5 523.25
#define FREQ_D5 587.33
#define FREQ_E5 659.25
#define FREQ_F5 698.46
#define FREQ_G5 783.99
#define FREQ_A5 880.00

const float freqs[] = {FREQ_C5, FREQ_D5, FREQ_E5, FREQ_F5, FREQ_G5, FREQ_A5};

void setup()
{
  for (int pin = FIRST_BUTTON; pin <= LAST_BUTTON; pin++)
    pinMode(pin, INPUT);
}

void loop()
{
  int button = 0, freq = 0;
  for (int pin = FIRST_BUTTON; pin <= LAST_BUTTON; pin++) {
    if (digitalRead(pin) == HIGH) {
      button = pin - FIRST_BUTTON;
      freq = int(freqs[button]);
      tone(BUZZER_PIN, freq, 100);
    }
  }
  delay(100);
}
```

Question 10)

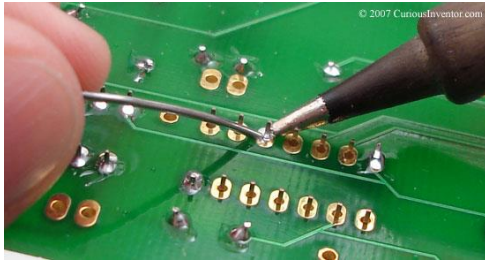

Soldering is a very good method of permanently joining electronic components to the copper tracks on a PCB. Soldering is completed by heating the component and track at the same time, solder wire is then applied (this is a mixture of tin and lead) which then bonds to the surfaces of the tracks and component through the wetting process. This provides a very strong electrical connection for the production of PCBs. It provides a quick easy method joining components.

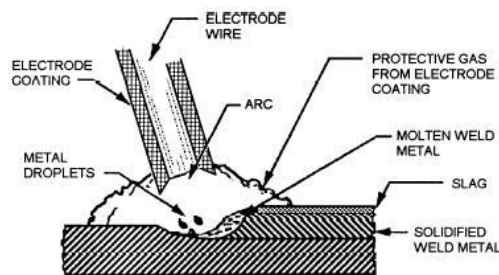

Arc welding is a process of joining two metals together using high current to melt the electrode as well as the surface of the two metals being joined. This creates an extremely strong, permanent joint. It is a very quick process, but is not suitable for softer metals, such as aluminium due to the high temperatures produced during the process. The welding process also gives off harmful UV light, so eye protection is a must (usually a welding mask) as well as protective clothing.



Nuts and bolts are a very good method for creating joints that can be separated (temporary). They provide a strong joint which can withstand the forces applied to it. The joint is very strong, however, the process involves drilling holes into the material for the bolt to go through, this weakens the material which can not be repaired.

Question 11)

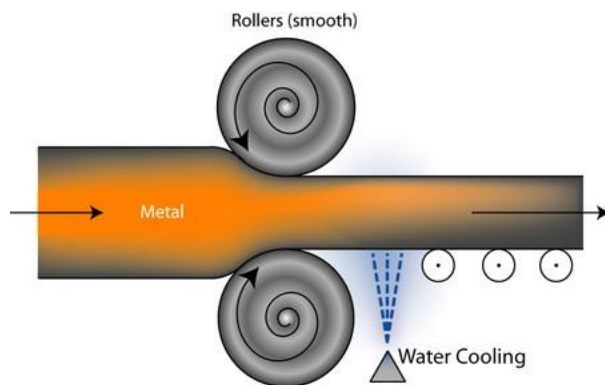

The process of making the body of a saucepan starts with an ingot of metal, usually aluminium. Aluminium is a light weight material that has very good heat absorption properties. Stainless steel would also be a good alternative. This is then run through heated rollers where the material is stretched out into a thin sheet of metal of the same thickness. This is called the deformation process. Once the sheet has been rolled into a thin sheet, it will be cut into round shapes and pressed into the standard saucepan shape using a punch press. Once the pan has been cut and pressed into shape, it would then need to be cleaned (usually with sodium hydroxide which opens the pores of the metal) and then coated with a high heat resistant coating to prevent corrosion of the material, this could be enamel. This process could be used to batch produce multiple saucepans. Batch production would be the best option as the sheets produced by the ingots would not allow for continuous production.

Question 12)

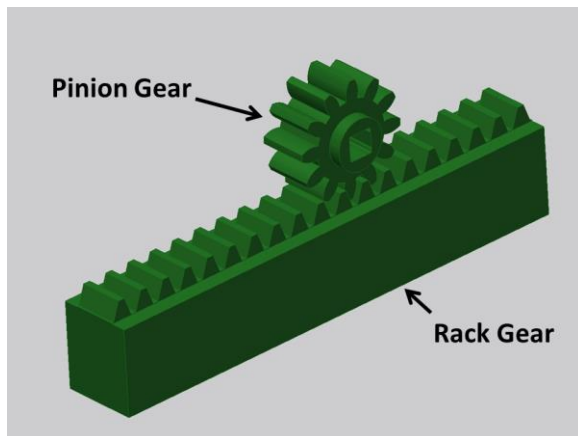

The first method of converting rotary motion to linear motion would be a rack and pinion system. The system could be run from a DC motor or stepper motor if you need more control. The speed and torque of the motion would be determined by the gearing of the motor and the type of motor being used. The system would require maintenance, cleaning to ensure there is no dirt in the gearing and lubrication to reduce friction caused by the gear movement. This is a very reliable system as long as the pinion gear and rack are mounted accurately and allow for free movement. The length of the rack can be adjusted to nearly any length. The control of the output can be done using optic sensors or micro switches.

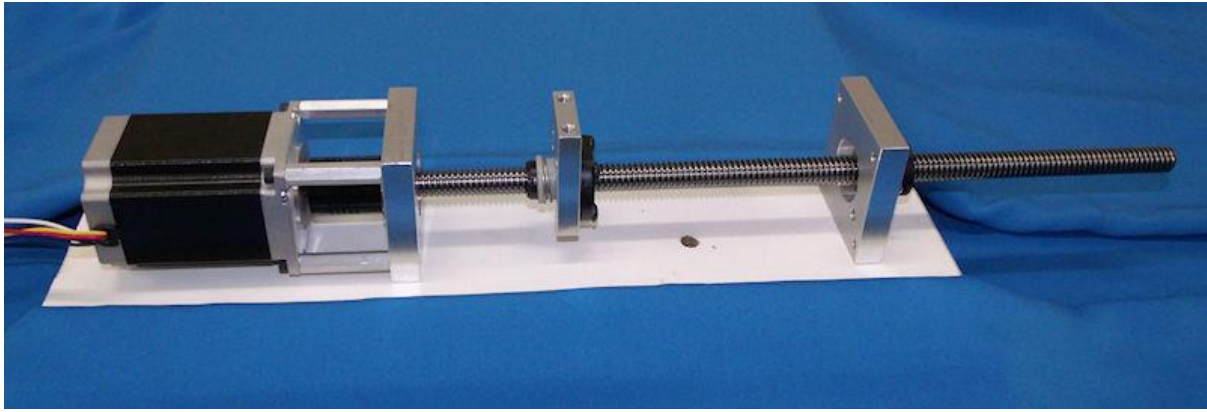

A drive nut and lead screw system could be used to convert rotary motion into linear motion. This is done by attaching a motor (usually stepper motor) to the lead screw and then the drive nut is attached to the object that needs moving in the linear direction. The opposite end of the lead screw is fitted into a bearing, to ensure the screw stays in in the correct plane. This system allows for very accurate movement, but at low speed. The speed of the system can be changed by changing the step speeds of the motor and the precise control of the rotation of the motor can be done by counting the number of steps. The lead screw will need regular cleaning and lubrication to ensure smooth motion.