

June 2011 – Model Solution

Section 1

1.1. With the aid of annotated sketches describe suitable tests that could be carried out to compare:

- tensile strength across a range of metals
- hardness across a range of metals
- electrical resistance across a range of metals
- resistance to corrosion across a range of metals.

For each test you should indicate:

- the approximate size of the sample
- how the test is carried out
- the data that needs to be collected
- the method of collecting the data
- how the data is analysed. (4 x 7 marks)

Tensile Strength. Each metal to be tested would be a consistent size – 150mm x 20mm x 1mm, with 4mm holes drilled through the sample (so it can be suspended) at each of the two ends. To conduct the test, the sample is suspended from a load-bearing point, and 500g masses are incrementally added to the bottom hole, until the sample fails. After each addition of mass, the amount of stretch on the sample (if any) is recorded. This data is recorded on a spreadsheet, so that when all samples have been tested, a bar graph showing ultimate tensile strength can be produced, or a line-graph showing the amount of distortion against the amount of mass applied to the sample.

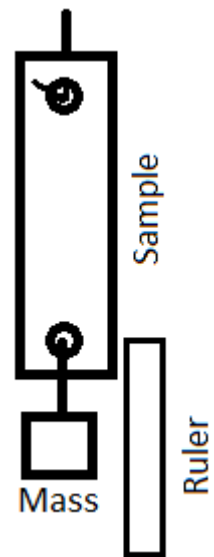

Hardness. To measure the scratch hardness of a metal, a pointed tungsten carbide tip exerting increasing amounts of force (known as a sclerometer) should be drawn across the surface of each sample, and the amount of force required to leave a mark should be noted for each. Once the samples have all been tested to the point when they mark the sample, the results can be sorted into rank order, and plotted onto a bar graph. As only the surface is being tested, the samples can be small (e.g. 50mm x 20mm x 1mm).



Electrical Resistance. All metals are good conductors. To discern the relative resistance from one to another, a standard multimeter Ohmmeter wouldn't be suitable, so a specialist high-precision model would be needed. The samples would all need to be a consistent size – 1mm thick wire versions (if available) would be ideal. The probes should be placed 50mm apart, so that the test is consistently fair. Once all the readings have been taken, the results can then be sorted into rank order, and presented on a bar graph so the relative resistance can be seen visually.

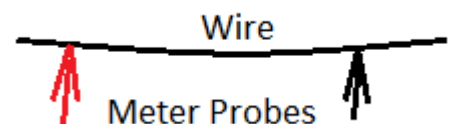

Corrosion Resistance. Many chemicals can cause corrosion in metals (e.g. exposure to acids), but the most common corrosion to occur in metals is probably oxidation in air/water, which my test will look at. To test the resistance, samples measuring 150mm x 20mm x 1mm can be 50% suspended in water (at a consistent room temperature for each test), so that half is still exposed to air. The samples can be then left, and inspected every 24 hours. Over time, the samples will start to discolour. The percentage of the surface areas which is exposed to corrosion can be logged at each sampling point, and all the samples can be plotted onto a line graph (time vs coverage), so that the characteristics of all the samples can be compared.

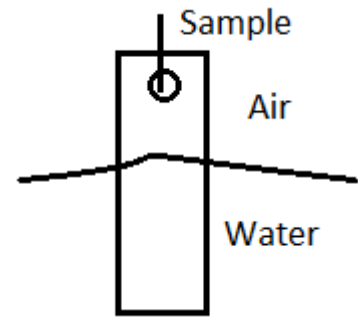

2. Suggest appropriate materials for each of the following products. Give specific reasons for your choice, making reference to the products' function, manufacturing processes and the scale of production.

2.1. The main body of a vice suitable for holding metal (7 marks)

As high tensile strength is needed (the vice will need to exert a large amount of force on the materials it is holding), as well as toughness (a workshop environment can see equipment receiving knocks and bumps). This is why vices are normally made from cast iron. The shape of the mould is formed as a mould, and molten metal is poured into the mould, which is then allowed to cool and set. To help the vice resist corrosion, it would then be painted. Using this method, the vices can be mass-produced easily.

2.2. A food preparation board (7 marks)

While oak provides an aesthetically pleasing traditional look for a board, they can harbour bacteria in the grooves that are cut into them by Chefs' knives. A chopping board for commercial use would need to be colour co-ordinated (e.g. red for meat), and so a hard-wearing material such as polypropylene (PP) or ABS would be suitable. Either of these could be injection moulded, to allow for convenient batch or mass production.

2.3. The lens in a pair of safety goggles (7 marks)

The lens would need to offer some degree of impact and chemical resistance, and would also need to be transparent. As they are likely to be put down carelessly from time to time, good hardness would help prevent the lenses from being scratched. Acrylic is available in a wide variety of thicknesses, and could be vacuum formed to an ergonomic shape easily (for batch/mass production), or If a flat lens is to be used, the material could be laser-cut, which again would lend itself to volume production.

2.4. A cooking container suitable for use in a domestic oven (7 marks)

A material to be used in a domestic oven would need to be able to stay solid in sustained temperatures of up to 250°, and to be sufficiently hard so as not to be easily damaged by scouring (when being cleaned). Additionally, the material should not be susceptible to imparting chemical coatings or flavours into food. Stainless steel cookware would be corrosion resistant, easy to clean, and a good conductor of heat. The bottom and two of the sides of the sheet would be punched out using a blanking process, then the sides folded up. The remaining two sides could also be cut in the same way, and then the edges welded together to complete the tray.

3.1. With the aid of sketches, describe in detail a method of producing complex 3D forms in thermoplastic using a redistribution process. (10 marks)

Redistribution is the process of taking a material and forming it into a new shape, so there is no waste. Injection moulding and vacuum moulding are examples, as is 3D printing, which I will discuss.

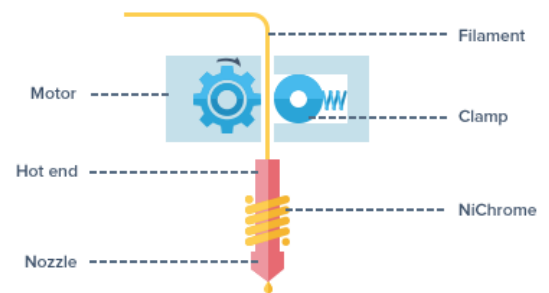

After a 3D model has been designed on a CAD package, the 3D printer works by an extruder unit drawing filament (e.g. ABS or PLA) in from a reel, and melting it. A raft of ABS is laid onto the pre-heated bed of the printer, then a pair of stepper motors are used to move the extruder around to create an individual layer (called a slice) of liquid plastic. Once the slice has been drawn, the bed moves down a fraction of a millimetre, then the next layer is drawn. Each layer cools and solidifies before the next is drawn, slowly forming highly detailed 3D shapes.

3.2. With the aid of sketches, describe in detail a method of producing complex 3D forms in a metal using a forming process. (10 marks)

Forming processes are those which use mechanical deformation to work with metal, such as rolling, forging or extrusion. I will talk about extrusion. This is the process of driving molten metal (e.g. steel) through a template in order to produce 3D parts of a consistent cross section (e.g. for parts of double-glazing unit frames). In the sketch, the final product can be seen made as a result of passing the blank through the die.

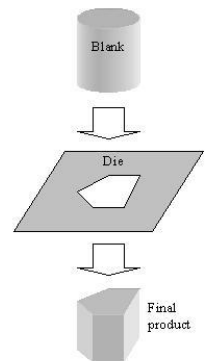

3.3. Describe four advantages of using fabrication as a method of producing products. (4 × 2 marks)

Fabrication is the process of combining different parts together to produce a product.

Advantage 1: Larger products can be produced than could be made by individual smaller parts.

Advantage 2: Individual parts can each be made from the best possible material each with its own properties as required by the design brief.

Advantage 3: Fabricated products can usually be disassembled. This may be required for maintenance when parts fail, extending the product life.

Advantage 3: Individual parts can be manufactured in multiple sites, so best value can be obtained, and specialist parts obtained when not locally available.

Advantage 4: Individual parts will be more readily transportable than large, assembled systems.

Continued over...

Section 2

4.1. With the aid of sketches describe in detail two different methods of converting the energy from the sun into electrical power. Your answer should clearly show the energy conversions that take place. (2 x 8 marks)

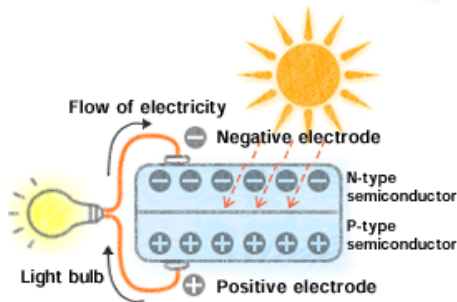
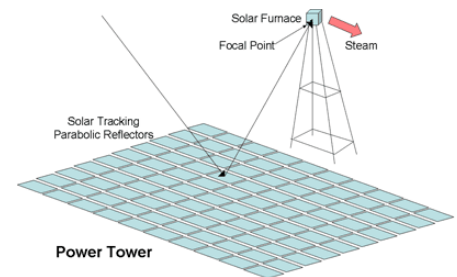

Photo-Voltaic cells work when sunlight hits the semi-conductor (see sketch), an electron springs up and is attracted to the n-type semiconductor. This causes more negative electrons in the n-type semiconductor and more positive electrons in the p-type, thus generating a flow of electricity in a process known as the “photovoltaic effect.”

A **Solar Furnace** works by having a series of parabolic reflector mirrors which automatically track the sun, and focus the concentrated light on a focal point. An enormous amount of heat is generated at this point, which can be used to boil water, in term generating high-pressure steam. This in term can be used to drive a turbine for the production of electricity.



4.2. Discuss the suitability of gas and wind power as methods of generating electrical energy in the UK. Make reference in your answer to continuity of supply, setup costs, operating costs and pollution. (12 marks)

Gas is a fossil fuel (and burning it produces greenhouse gasses), as such is not finite. While fracking has the potential to secure the UKs energy needs for around 10 years, UK dependency on imported gas would expose citizens to potentially volatile price fluctuations. One advantage over wind is that gas is available regardless of weather conditions.

Wind power can be quickly erected in multiple sites and produce little pollution (after the initial outlay of energy and materials to manufacture them), although some are critical of the turbines, citing that they spoil the natural environment, and can be noisy. As previously alluded to, wind doesn't blow at the correct speed all the time, and so they can't be used as the sole source of UK power.

5.1. Describe in detail the advantages and limitations of using direct current motors and stepper motors for applications where precise linear movement is required. (16 marks)

DC Motors: Available in many sizes, these work at many voltages and are cost effective to reduce setup cost. The direction of the motors can be easily reversed by reversing the polarity.

Limitations of DC motors are that they tend to run at high speed and with low torque, so as a result they need gearing down to reduce speed to something more practical for producing precise movement. As their output is rotary, a system will be needed to convert the motion to linear. DC motors are also able to rotate when powered off (so the position can be lost), and they don't stop immediately (over run) when switched off. In order to know the amount of linear movement, a sensing system is needed.

Stepper Motors: These move in precise steps (e.g. 1.8°), so their movement can be precisely controlled. When not moving, the output shaft can be locked in place. By powering the coils in reverse order, their direction of travel can be easily reversed.

Just like with DC motors, the output is rotary, so this will still need a system to convert to linear motion. Steppers have a low maximum speed, need ramping (starting by rotating slowly, then increasing the speed) for accurate control.

5.2. With the aid of a diagram, show how accurate angular movement can be achieved using a direct current motor and a feedback system. (12 marks)

A pinion gear is attached to the output spline of the DC motor, and four holes are drilled into the side of the gear.

The gear is then mounted, with an LED and LDR fixed in permanent positions in line with the holes. The LDR is connected to the analogue input on a PIC chip, so that the IC will be able to detect each 90° of rotation.

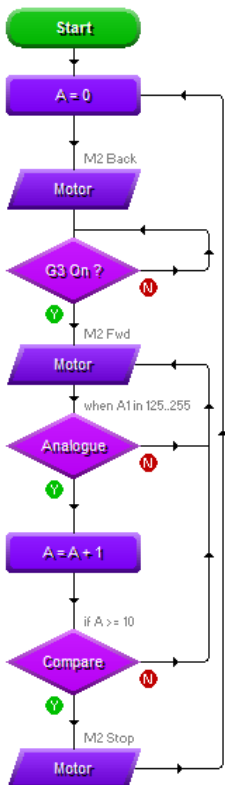
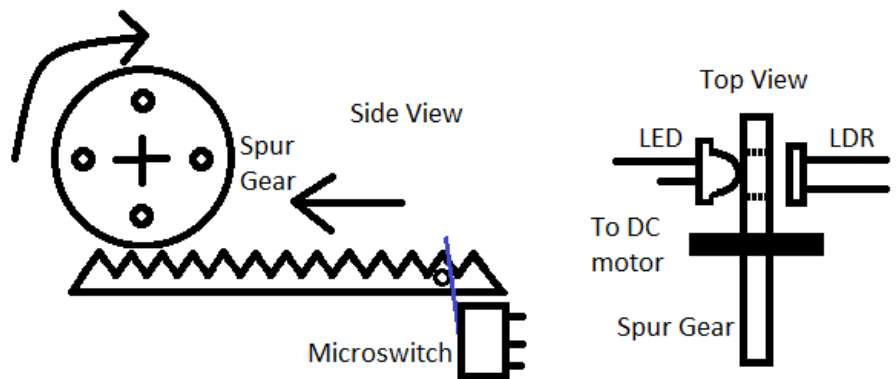

The spur gear is meshed onto a rack gear, which will provide the required linear motion. Upon system start-up, the DC motor will be energised to turn anti clockwise, until the micro-switch is depressed by the protruding part on the rack. This will calibrate the unit, so that the starting position is known. It can then rotate in the opposite direction, with each quarter turn being detected, and a count stored in a variable on the PIC.

The control circuit would look like this. It uses an L293d half-H bridge driver connected to the DC motor (so its direction can be reversed easily), and the PIC to count the rotations. The micro-switch is represented by a PTM switch in this diagram, and the LED is included in the circuit too. Additionally, a SPST switch could be incorporated into the circuit to control the master power.

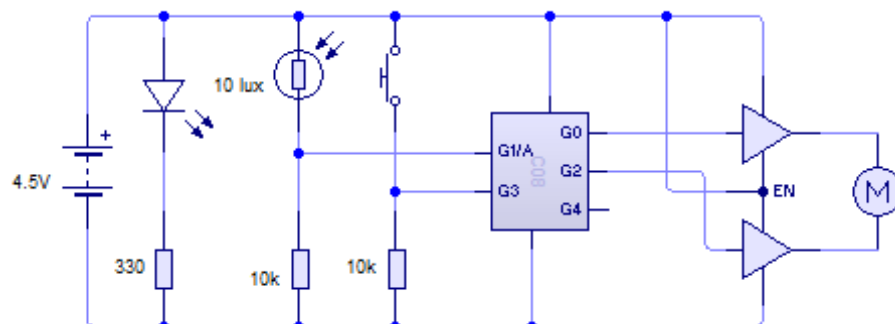

6.1. Describe with reasons, four pieces of anthropometric data that would need to be taken into account when designing a bicycle. Use annotated sketches to support your answer. (4 x 4 marks)

Average adult hand-span from thumb to first two fingers. When the user wishes to apply the brakes, if this distance is too short, then insufficient movement will be available to transfer adequate force to the brake pads to make them effective. If they are too far away from the user's hand, they won't be able to grip the handlebar and brake handle simultaneously in order to apply the brake.

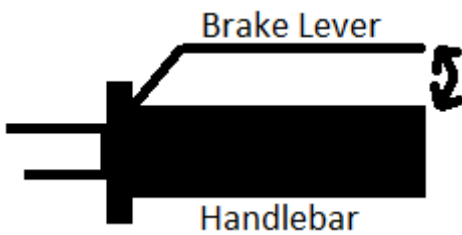
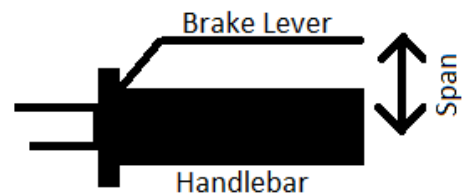

Hand strength. Still on the subject of braking, if the amount of force required to apply the brake effectively is greater than the average human grip strength, then the bike would be unsafe to operate.

Range of weights of men/women for each frame size. This will dictate the thickness of material (likely to be steel) that will be needed during construction to provide suitable structural rigidity, so that the frame doesn't buckle during operation. The sketch shows the individual pieces of tube steel in a frame.

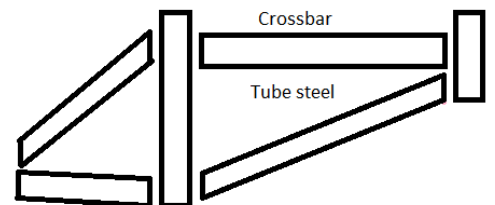

Range of leg-lengths (hip to knee and knee to foot) for children and adults (male and female). This will dictate the size of the frame, as well as the size of the wheels to be fitted to the cycle, and also the length of the crank-arms that the pedals are connected to.

In the sketch, the rider's feet comfortably reach the pedals, and when their legs are extended, their feet will just touch the floor. The saddle can be designed to be adjustable to fine-tune this for individual users.

6.2. With the aid of sketches, describe in detail a method of comparing the performance of bicycle braking systems in a school workshop. (12 marks)

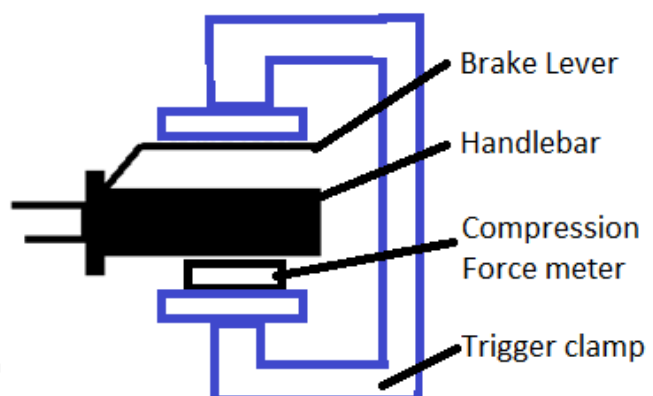
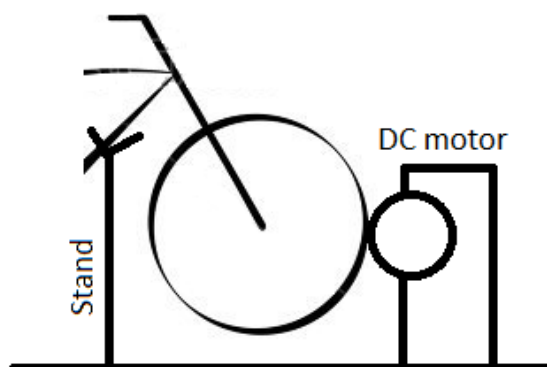

In this design, the cycle to be tested is first immobilised by being placed in a stand, and the front wheel pushed up against another wheel mounted to a 24V DC motor. With the cycle secured, a trigger clamp (with a compression force meter under one of the pads) is positioned over the brake lever, ready to exert increasing amounts of force onto the brake when the test is commenced.

To test each brake configuration, the DC motor is first energised until the cycle wheel is brought up to full speed. The trigger clamp can then be slowly applied, until sufficient force is imparted that it stops the wheel completely. The amount of force required is recorded, and then the test can be repeated for the next cycle.

Once all cycles are tested, the results can be sorted into order, and plotted on a bar graph, so that their relative performance can be seen.